

MODEL OF THE STRUCTURE OF AND THE EFFECTIVE THERMAL
CONDUCTIVITY OF A BAZHENOV SUITE

G. N. Dul'nev, T. V. Dorofeeva,
D. P. Volkov, and B. L. Muratova

UDC 550.362

A model of the structure of a Bazhenov suite and a method for calculating its effective thermal conductivity are proposed.

One of the promising oil fields in the Soviet Union is the deposits of the Berias-Volga stage of Western Siberia. They consists of nontraditional rock reservoirs, called a Bazhenov suite. A Bazhenov suite consists of mudstone formations, which were for a long time believed to be fluid supports. The commercial oil flow obtained from Bazhenov rocks in Middle Basin of the Ob' river marked the beginning of the commercial development of the deposits and stimulated the study of the reservoir characteristics of mudstone formations.

One of the characteristic features of oil deposits in the Bazhenov suite is that there is no relationship between the occurrence of deposits and the structural relief, i.e., the contours of the oil deposit cannot be determined accurately by modern geophysical methods and they cannot be established without wells. But existing drills and core extractors destroy during the drilling process the loose bazhenites, and cores whose collector properties do not correspond to the conditions of the reservoir are raised to the surface.

In this work a model is proposed for the structure of a Bazhenov suite, the relationship between the structure (porosity or emptiness, oil content) and the thermophysical properties of the rock is found, and the characteristics obtained are checked under laboratory conditions and then extrapolated to reservoir conditions.

Detailed complex studies, first performed for rocks in the reservoirs of mudstone formations for the example of deposits of a Bazhenov suite, showed that their volume consists largely of voids of different origin in the matrix and that filtration in the rock reservoir occurs along cracks and associated pores, but its magnitude is determined primarily by the degree of fissuring.

According to the investigations of [1], Bazhenov rocks contain the following basic components: sapropel organic matter (general concentration 22.5%); argillaceous and aleurite material (34.5%); authigenic, predominantly organogenic, silica (29.5%); dolomite (7.5%); calcite (3.5%); and pyrite (2.5%).

The starting material of Bazhenov rocks, which are most often of a lumpy character, is organic silt. In the process of formation of the rock its constituent organogenic silica is partially or completely dissolved and sorbed by the clay particles; the plasma parts of the organisms (radiolarions) are transformed at the same time and only the contours consisting of argillaceous-organic matter remain from the skeletons of the radiolarions. The remainder of the free silica (43%) is scattered in the silica-clay-organic mass. The radiolarions are cemented by argillaceous matter with hydromicaceous and hydromontmorillonite compositions, sometimes containing significant admixture of kaolinite. Calcium, dolomite, and pyrite are encountered in the rocks in the form of fine uniformly distributed grains, forming in many cases significant accumulations. The following are observed in the cemented bunches and lumps: 1) primary sedimentation pores of organomineral mass; 2) diagenetic pores, formed by kaolinization and calcification; 3) leaching ores; and 4) intertextural microcracks, developed along the peripheries of the bunches and lumps, along the laminations of argillaceous minerals. Intertextural cracks, connecting pores, create a single three-dimensional rock reservoir system.

Leningrad Institute of Precision Mechanics and Optics. Translated from *Inzhenerno-Fizicheski Zhurnal*, Vol. 52, No. 1, pp. 108-116, January, 1987. Original article submitted August 29, 1985.

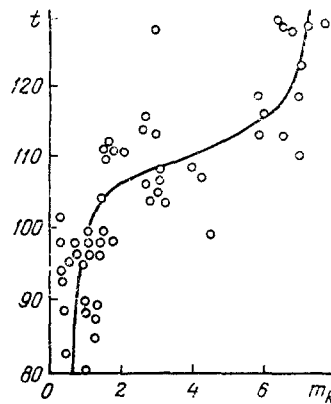

Fig. 1. Open porosity of Bazhenov rocks versus the temperature of the formation. The dots are the experimental points and the curve is the average dependence. t , °C; m_k , %.

The pores and cracks vary in size from 2 to 10 μm and 1 to 5 μm , respectively. The distance between horizontal cracks is 7 to 10 mm, the distance in the lamellar varieties extends up to 1 mm, and the distance between the vertical (steep) cracks is on the average 15 to 20 mm.

Bazhenov rocks are characterized by the presence of organic matter not only in the pores but also in the framework. For formation temperatures above 100°C hydromicatization of montmorillonite occurs in the organic matter (OM) of the rocks, and then the bitumoids are transformed into a state which is independent of the rock. For this reason the structure of the rocks and their open porosity are largely determined by the temperature of the stratum. At 100°C and higher some of the OM in the framework of the rock is transformed into a liquid fraction, thereby increasing the open porosity (Fig. 1).

In addition to the open porosity, which determines the relative fraction of the mobile oil, Bazhenov rocks also contain cavities, occupied by the residual oil (residual oil saturation). The residual oil saturation is represented, as a rule, by the heaviest fractions of the oil, trapped in narrow capillaries or blind pores, oil film adsorbed on the rock, etc., so that for Bazhenov rocks it is more accurate to call it the residual "bitumen saturation." It is obvious that the total porosity must be interpreted to be the sum of the open porosity and the residual bitumen saturation. Table 1, constructed from the data of [1], shows the average indicators of a Bazhenov suite.

Let us return to the structure of Bazhenov rocks. Photographs of samples of argillaceous deposits, made in an electron microscope, clearly show the lepidoblastic nature of the structure of the material, which makes it possible to represent the structure of the rocks in the Bazhenov suite as follows (Fig. 2). The plates and leafs 1, consisting of silica, argillaceous material, and less frequently carbonate material, between which bitumens 3 are often situated, in contract with one another along the areas 2 form a porous matrix, whose pores contain free 4 and bound 5 hydrocarbons. Free silica, calcite, dolomite, and pyrite 6 are observed in the matrix in the form of separate isolated inclusions. The matrix is crisscrossed with cracks 7, whose volume is small and on the average constitutes not more than 3%. Unlike the pores, the cracks in the rocks formed as the physical loads on the rocks changed, as a result of which their volume is independent of the temperature of the stratum.

We shall represent the structure of the rocks in a Bazhenov suite by a simplified model, which retains the basic features of the real structure (Fig. 3). We shall represent the plates in the form of square plates 1, in contrast with one another along small areas 2. The plates are connected to one another by organic matter 3. The pore space is distributed between the open porosity 4 and the closed (residual oil saturation) porosity 5. The silica, calcite, dolomite, and pyrite are distributed uniformly in the form of cubic inclusions 6 in proportion to their volume concentration. The cracks 7 form a uniform structure in the form of interpenetrating components with constrictions (fissured structure).

We shall examine the process of heat transport through this model and, employing the methods of the theory of generalized conductivity, we shall derive an analytic expression

TABLE 1. Characteristics of Rocks in a Bazhenov Suite [1]

Volume concentrations		Argillaceous-organic fraction $\frac{V_{ao}}{V} = 0,97$					Cracks $\frac{V_{cr}}{V} = 0,03$
Thermal conductivity, $W/(m \cdot K)$	$\lambda_{no} = 0,13$ [5]	$\lambda_b = 0,95$ [6]	$\lambda_c = 3,0$ [4]	$\lambda_{sil} = 3,0$ [4]	$\lambda_d = 3,0$ [4]	$\lambda_{ca} = 3,0$ [4]	$\lambda_p = 3,0$ [4]
	$\frac{V_{no}}{V_o} = 0,462$	$\frac{V_{ro}}{V_o} = 0,54$					
	Free	Residual					
	Oil	Bitumoid					
	$\frac{V_o}{V_{so}} = 0,573$	$\frac{V_b}{V_{so}} = 0,427$		Bound $\frac{V_{bs}}{V_{os}} = 0,57$	Free $\frac{V_{fs}}{V_{os}} = 0,43$		
	$\frac{V_{so}}{V_{ao}} = 0,225$		Argillaceous and aleurite material $\frac{V_c}{V_{ao}} = 0,345$	Organogenic silica $\frac{V_{os}}{V_{ao}} = 0,295$	Dolomite $\frac{V_d}{V_{ao}} = 0,075$	Calcite $\frac{V_{cal}}{V_{ao}} = 0,035$	Pyrite $\frac{V_p}{V_{ao}} = 0,025$

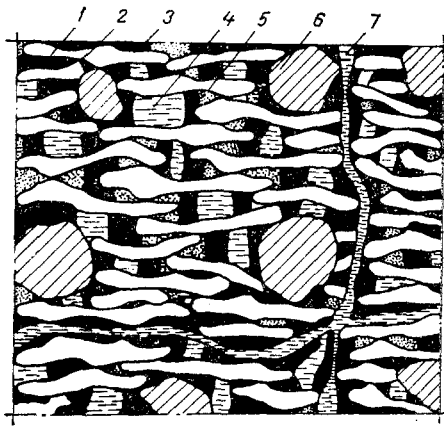

Fig. 2. Structure of the rocks in a Bazhenov suite.

for its effective thermal conductivity [2]. It is useful to carry out the analysis in several stages.

Stage I. We shall determine the thermal conductivity of the matrix I, consisting of bound silica, an argillaceous fraction, and organic matter. Following the method of [2], we separate out a unit cell in the model (Fig. 4), consisting of one-fourth plates 1 with a contact area 2, solid bitumens 3, and one-fourth pores 4. We divide the cell with infinitely thin (adiabatic) interlayers through which the heat does not penetrate and we shall determine, as in the case of flat walls, the thermal resistance for each section [2]:

$$R_i = l_i / (S_i \lambda_i). \quad (1)$$

We connect the thermal resistances in a circuit (Fig. 5) and calculate the total resistance R of the unit cell:

$$\frac{1}{R} = \frac{1}{R_2} + \frac{1}{R_1 + R_5} + \frac{2}{R_3} + \frac{1}{R_4}, \quad (2)$$

$$R_2 = \frac{h}{\bar{a}_2 \lambda_c}, \quad R_1 = \frac{h_1}{(\bar{d}^2 - a^2) \lambda_c}, \quad R_3 = \frac{h}{(L - \bar{d}) \bar{b} \lambda_b},$$

$$R_4 = \frac{h}{[L^2 - \bar{d}^2 - 2(L - \bar{d}) \bar{b}] \lambda_{no}}, \quad R_5 = \frac{h - h_1}{(\bar{d}^2 - a^2) \lambda_{ro}}, \quad R = \frac{h}{L^2 \lambda}.$$

We denote

$$v_b = \lambda_b / \lambda_c, \quad v_{no} = \lambda_{no} / \lambda_c, \quad v_{ro} = \lambda_{ro} / \lambda_c, \quad a = \bar{a} / L, \quad b = \bar{b} / L, \quad (3)$$

$$d = \bar{d} / L$$

and we assume, based on visual observations, that $h' = (h - h_1) / h = 1/5$. Substituting (3) into (2), we obtain

$$\lambda' / \lambda_c = a^2 + 5v_{ro} (d^2 - a^2) / (4v_{ro} + 1) + 2(1 - d) b v_b + v_{no} [1 - d^2 - 2b(1 - d)]. \quad (4)$$

The dimensions of the unit cell are related with the volume concentrations of the components. We denote

$$\alpha = \frac{V_{no}}{V}, \quad \beta = \frac{V_b}{V}, \quad \gamma = \frac{V_c}{V}, \quad \delta = \frac{V_{ro}}{V}, \quad (5)$$

where

$$V = L^2 h; \quad V_c = h_1 \bar{d}^2 + (h - h_1) \bar{a}^2; \quad V_b = 2h \bar{b} (L - \bar{d}); \quad V_{ro} = (h - h_1) (\bar{d}^2 - \bar{a}^2); \quad V_{no} = V - V_c - V_{ro} - V_b = h [L - \bar{d}^2 - 2\bar{b} (L - \bar{d})]. \quad (6)$$

It is easy to obtain from the expressions (5) and (6) the dependences

$$\alpha = 1 - d^2 - 2b(1 - d), \quad \beta = 2b(1 - d), \quad \gamma = 0,2(4d^2 + a^2), \quad (7)$$

$$\delta = 0,2(d^2 - a^2).$$

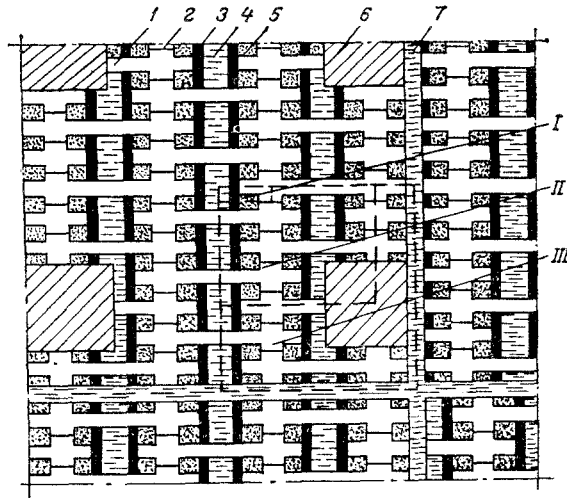

Fig. 3. Model of the structure of a Bazhenov suite; I, II, and III are the stages in the determination of λ .

Using (5) and (7), we represent the expression (4) for the effective thermal conductivity λ' of the matrix in the form

$$\lambda'/\lambda = \gamma - 4\delta + \beta v_b + \alpha v_{no} + 25\delta v_{ro}/(1 + 4v_{ro}). \quad (8)$$

Stage II. We are studying the structure II consisting of a continuous matrix and isolated inclusions. We shall employ the well-known dependence of the effective thermal conductivity of such structures [2] on the thermal conductivity λ_{kj} and concentration m_k of the components j, k :

$$\frac{\lambda_i}{\lambda_j} = 1 - \frac{m_k}{\frac{1}{1 - v_{jk}} - \frac{1 - m_k}{3}}, \quad v_{j,k} = \frac{\lambda_k}{\lambda_j}. \quad (9)$$

We shall calculate based on the formula (9) the thermal conductivity of the mixtures: a) λ'_{sil} , whose components are the continuous matrix with thermal conductivity λ' and free silica; b) λ'_{cal} , one of whose components is the continuous matrix with silica (λ'_{sil}) and the other calcite (λ_{cal}); c) λ'_d , the thermal conductivity of one component is λ'_{cal} and that of the second is the thermal conductivity of dolomite; d) λ'' , the thermal conductivity of one component is λ'_d and that of the other is λ_p . The result of the calculation at the second stage is an effective thermal conductivity of the matrix containing inclusions of free silica, calcite, dolomite, and pyrite λ'' .

Stage III. We determine the effective thermal conductivity of the other system (rock) III. The Bazhenov suite is a medium consisting of cracks and pores, one component of which is the framework with thermal conductivity λ'' and the other is cracks filled with oil. The formula for the effective thermal conductivity of the fissured structure is presented in [3] and has the form

$$\lambda/\lambda'' = c^2 M + v(1 - c)^2 + 2vc(1 - c)/(vc + 1 - c), \quad (10)$$

where $c = f(m_{cr})$, $v = \lambda_o/\lambda''$; and M for strongly fissured structures equals c^2 .

We shall study an example of the calculation of the effective thermal conductivity of a typical sample of rock in a Bazhenov suite using the method proposed. The starting data for the calculation of the volume concentrations are taken from Table 1.

Stage I. We calculate the thermal conductivity of the matrix, consisting of clay and aleurites (V_c), bound silica (V_{bs}), and sapropellite organic matter (V_{so}). We denote the volume of this matrix by V' , $V' = V_c + V_{bs} + V_{so}$. The volume concentrations of the components of this matrix, according to the definition (5), will be as follows: solid component, i.e., clay, aleurites, and bound silica, appearing as a constituent of the clay, $\gamma = (V_c + V_{os})/V' = 0.70$; solid (immobile) bitumoids $\beta = V_b/V' = 0.13$; free oil $\alpha = V_o/V' = 0.08$; and, bound oil (residual oil saturation) $\delta = V_{ro}/V' = 0.09$. We find the ratios of the thermal

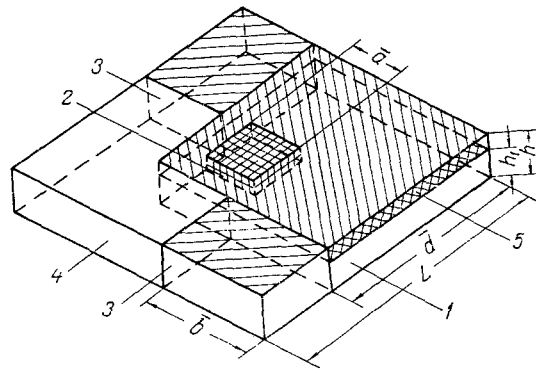

Fig. 4. Unit cell: 1-5) sections of the unit cell.

conductivities (3), appearing in the formula (8): $v_{no} = \lambda_{no}/\lambda_c = 0.13/3.0 = 0.04$; $v_{ro} = \lambda_{ro}/\lambda_c = 0.04$; $v_b = \lambda_b/\lambda_c = 0.95/3.0 = 0.32$. Using the formula (8) we calculate the thermal conductivity of the matrix λ' :

$$\begin{aligned} \lambda'/\lambda_c &= 0,70 - 4 \cdot 0,09 + 0,13 \cdot 0,32 + 0,08 \cdot 0,04 + 25 \cdot 0,09 \cdot 0,04 / (1 + 4 \cdot 0,04) = \\ &= 0,49; \quad \lambda' = 3,0 \cdot 0,49 = 1,47. \end{aligned}$$

Stage II. We calculate the thermal conductivity λ'_{sil} of a mixture consisting of the continuous matrix (V') with the thermal conductivity $\lambda' = 1.47$ and inclusions of free silica (V_{fs}), using the formula (9). The volume concentration of the inclusions of free silica $m_k = m_{fs} = V_{fs}/(V' + V_{fs}) = 0.15$; the ratio of the thermal conductivity of the inclusions and the matrix equals

$$\begin{aligned} v_{i,h} = v_{fs} &= \lambda_{fs}/\lambda' = 3,0/1,47 = 2,04, \text{ then} \\ \lambda'_{sil}/\lambda' &= 1 - 0,15/(1/(1 - 2,04) - (1 - 0,15)/3) = 1,12; \quad \lambda'_{sil} = \\ &= 1,47 \cdot 1,12 = 1,64. \end{aligned}$$

Analogously, using the formula (9), we calculate the thermal conductivity of the mixture with calcite inclusions λ'_{cal} :

$$\begin{aligned} m_k = m_{cal} &= V_{cal}/(V' + V_{fs} + V_{cal}) = 0,04; \quad v_{jh} = v_{cal} = \lambda_{cal}/\lambda'_{sil} = \\ &= 3,0/1,64 = 1,83; \quad \lambda_{cal} = 1,64 (1 - 0,04/(1/(1 - 1,83) - (1 - 0,04)/3)) = 1,68; \end{aligned}$$

with dolomite inclusions $\lambda'_d = 1.76$;

with pyrite inclusions $\lambda'_p = 1.87 = \lambda''$.

Stage III. The rock sample is permeated with cracks, whose volume concentration equals 3%. From the formula (10) we calculate the effective thermal conductivity of the entire rock. Based on the formulas presented in [2] we find

$$\begin{aligned} c = f(m_{cr}) &= 0,9; \quad v = 0,13/1,87 = 0,07; \quad \lambda/\lambda''' = 0,9^2 \cdot 0,9^2 + \\ &+ 0,07(1 - 0,9)^2 + 2 \cdot 0,07 \cdot 0,9(1 - 0,9)/(0,07 \cdot 0,09 + 1 - 0,9) = 0,73; \\ \lambda &= 1,87 \cdot 0,73 = 1,37. \end{aligned}$$

Using the proposed method we also calculated the thermal conductivity of specific samples of a Bazhenov suite, taken from different depths from the same well. For these samples only the composition of the solid phase (m_k) and the porosity (volume content of cracks m_{cr}) were known. In this approximation the thermal conductivity of such samples can be calculated as follows. At the first stage we assume that the thermal conductivity of the argillaceous-organic matter equals the arithmetic mean value of the thermal conductivity of the components, i.e., the average of the thermal conductivity of clay ($\lambda_c = 3$), bitumoids ($\lambda_b = 0.95$), and oil ($\lambda_o = 0.13$):

$$\bar{\lambda} = (3,0 + 0,95 + 0,13)/3 = 1,36.$$

At the second stage, using the formula (9), we determine the thermal conductivity of argillaceous-organic matter with inclusions of pyrite particles. For a sample taken from a depth of 2717 m, with a pyrite volume content of $m_k = 3\%$, $\lambda_j = 1.45$. At the third stage,

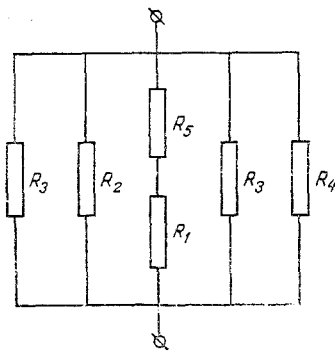

Fig. 5. Equivalent circuit of the thermal resistances of the unit cell: R_1 - R_5 are the thermal resistances of separate sections.

using the formula (10), we calculate the effective thermal conductivity of the fissured sample ($m_{cr} = 3.7\%$), and in addition the cracks in the sample contain air ($\lambda_a = 0.03$). The effective thermal conductivity equals $1.06 \text{ W/(m}\cdot\text{K)}$. The thermal conductivity of this sample, determined experimentally, equals $\lambda_{exp} = 0.94$. An analogous calculation was also performed for two samples taken from a depth of 2731 and 2741 m. The pyrite volume concentrations and the porosity equal, respectively, $m_k = 2$ and 5% and $m_{cr} = 1.8$ and 5.6% . For these samples the thermal conductivities calculated and determined experimentally are as follows: $\lambda_{calc} = 1.13$ and 1.01 ; $\lambda_{exp} = 1.10$ and 0.80 .

As we can see, the disagreements between the computed and experimentally determined values do not exceed 25%, which is comparable to the error in the starting data. Both the experimentally obtained and computed values were found at room temperatures and normal pressure. For conditions within the formation, values of the thermal conductivity of the samples of the Bazhenov suite will be different owing to the fact that, first of all, the cracks in the rocks contain oil instead of air and, second, the thermal conductivity of the components changes somewhat. A calculation using the method indicated above shows that under the conditions in the formation, i.e., at temperatures of the order of 100°C and a pressure of $50 \cdot 10^5 \text{ Pa}$, and the values of the effective thermal conductivity are 5 to 10% higher than at room temperatures.

The experimental measurements of the thermal conductivity were performed on the apparatus of [7], which is based on the comparative method. The sample had the form of a disk 40 mm in diameter and 6-10 mm thick.

As shown by lithological and geochemical studies, at temperatures above 105°C a sharp drop in blocked bitumoids is observed in Bazhenov rocks, which is explained by the transformation of the blocking asphalt-resin components, coinciding with a jumplike increase in the open porosity. With the transition of the blocked hydrocarbons into the free state, the volume which they occupied prior to the transition is automatically included in the open pore system and the structure of the pore space is transformed, owing to which the pore system becomes interconnected. There is a direct dependence between the open porosity and the temperature of the formation: the higher the formation temperature, the more intensively the process of unification of the blind pores and blocked pores into a single hydrodynamic system proceeds [1]. Therefore the thermal conductivity of the rock also depends sharply on the temperature.

Thus using the available experimental dependence between the formation temperature and the open porosity, the dependence between the temperature and the thermal conductivity both in the laboratory and under conditions in the formation can be determined using the method developed, which makes it possible to evaluate the thermal conductivity of Bazhenov rocks under natural conditions.

NOTATION

R and $R_{i_total_thermal}$ thermal resistance of the unit cell and the thermal resistance of separate sections; a , b , d , h , h_1 , L , S_i , linear dimensions and areas of the transverse, to the heat flow, sections of separate sections of the unit cell; λ_b , λ_c , and λ_o , thermal conductivities of bitumens, clays, and oil (hydrocarbons), $\text{W/(m}\cdot\text{K)}$; α , β , γ , δ , volume concentra-

tions of free hydrocarbons (oil), bitumens, argillaceous particles, bound hydrocarbons (residual oil saturation); V_i , volumes of separate sections; λ' , λ_{sil} , λ_{cal} , λ_d , λ'' , λ , thermal conductivities of mixtures of separate components and the effective thermal conductivity of the entire Bazhenov suite, W/(m·K); m_{cr} , volume concentration of the cracks; and c and M are parameters which depend on m_{cr} .

LITERATURE CITED

1. T. V. Dorofeeva (ed.), Oil Reservoirs of the Bazhenov Suite in Western Siberia [in Russian], Leningrad (1983).
2. G. N. Dul'nev and Yu. P. Zarichnyak, Thermal Conductivity of Mixtures and Composite Materials [in Russian], Leningrad (1974).
3. G. N. Dul'nev, Yu. P. Zarichnyak, and B. L. Muratova, Inzh.-Fiz. Zh., 31, No. 2, 278-283 (1976).
4. S. Clark, Jr. (ed.), Handbook of Physical Constants of Rocks [Russian translation], Moscow (1969).
5. Yu. L. Rastorguev, B. A. Grigor'ev, G. F. Bogatov, et al., Thermophysical Properties of Liquids [in Russian], Moscow (1976), pp. 24-26.
6. V. S. Chirkin, Thermophysical Properties of Materials Used in Nuclear Technology [in Russian], Moscow (1968).
7. V. V. Kurepin and A. F. Begunkova, Inzh.-Fiz. Zh., 29, No. 4, 241-247 (1975).

ANALYSIS OF THE CONJUGATE PROBLEM OF EVAPORATION FROM THE WALLS OF A LONG CHANNEL

V. I. Nosik

UDC 536.423.1

The conditions under which the nonequilibrium nature of the evaporation and redistribution of heat in the solid walls must be taken into account in order to calculate the heat and mass transfer in a long flat channel are determined.

The problems of evaporation from the walls of a long channel are encountered in the construction of models of physicochemical processes in porous media, as well as in the theory of heat pipes and dryers. There are two approaches to the solution of problems of this type. In the "energy" approach [1, 2] the intensity of the evaporation is determined based on the magnitudes of the heat flux flowing up to the evaporating surface, the pressure is assumed to be equal to the saturation pressure, and then the gas-dynamic problem with known blow-in intensity is solved and the distribution of the gas pressure and temperature of the evaporation surface T_0 is found. In the "kinetic" approach [3-5] the temperature of this surface is given and the pressure, gas velocity, and evaporation intensity are determined by the methods of the kinetic theory of gases. In the gas-dynamic limit (for small Knudsen numbers Kn) a relation of the Hertz-Knudsen type [6, 7], relating the flow rate with the temperature T_0 and gas pressure, is used; the pressure and flow rate are determined in the solution of the gas-dynamic problem.

Both approaches are limited, since they do not take into account the conjugate nature of the problem: the intercoupling of the heat transport in solid walls, the flow of vapor, and the kinetics of evaporation. Indeed, both the temperature of the evaporating surface (which is given in the kinetic approach) and the heat flow to it (in the energy approach) depend in the general case on the characteristics of heat transfer in the solid walls as well as on the characteristics of the flow and of the evaporation.

It is important to determine the region of applicability of these approximate approaches, clarify the necessity for using the conditions of nonequilibrium evaporation, and determine the region of "nonuniform" evaporation, when the redistribution of energy and the solution of the two-dimensional equation of heat conduction in the solid walls must be taken into account. The conjugate problem with uniform heat flow to the wall for low Reynolds' numbers of the